

Characteristics

The NG06 directional control valve series D1VW provides high functional limits up to 80 l/min in combination with a very low, energy-saving pressure drop.

A wide variety of spool options allows to design an unlimited number of hydraulic circuits.

Versions with 8 watt coils, position control, Atex approval, surface protection and connector variants are shown in the following chapters.

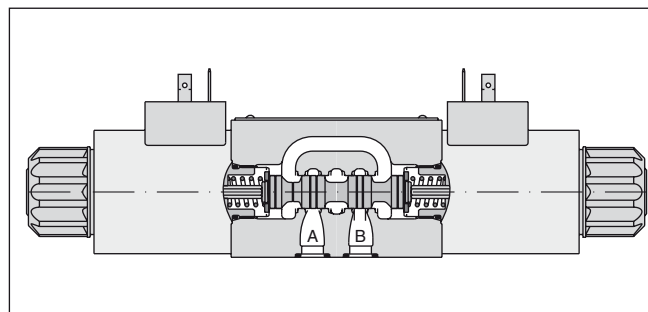
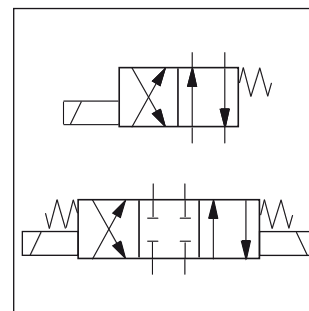

2

Technical data

General		Directional spool valve												
Design		Solenoid												
Actuation		DIN NG06 / CETOP 03 / NFPA D03												
Nominal size		DIN 24340 A6 / ISO 4401 / CETOP RP 121-H / NFPA D03												
Mounting interface		unrestricted, preferably horizontal												
Mounting position														
Ambient temperature		[°C]	-25...+50											
MTTF _D value		[years]	150											
Weight		[kg]	1.5 (1 solenoid), 2.1 (2 solenoids)											
Hydraulic														
Max. operating pressure		[bar]	P, A, B: 350; T: 210 (DC), T: 140 (AC)											
Fluid		Hydraulic oil in accordance with DIN 51524 / 51525												
Fluid temperature		[°C]	-25 ... +70											
Viscosity permitted		[cSt] / [mm ² /s]	2.8...400											
Viscosity recommended		[cSt] / [mm ² /s]	30...80											
Filtration		ISO 4406 (1999); 18/16/13 (meet NAS 1638: 7)												
Flow max.		[l/min]	80 (see shift limits)											
Leakage at 50 bar		[ml/min]	Up to 10 per flow path, depending on spool, up to 15 per flow path for spool type 008 + 009											
Static / Dynamic														
Step response		see table response time												
Electrical characteristics														
Duty ratio		100% ED; CAUTION: coil temperature up to 150 °C possible												
Max. switching frequency		[1/h]	15000 (not for soft shift)											
Protection class		IP 65 in accordance with EN 60529 (plugged and mounted)												
Code		<table border="1"> <tr> <td></td> <td>K</td> <td>J</td> <td>U</td> <td>G</td> <td>Y</td> <td>T</td> </tr> </table>							K	J	U	G	Y	T
	K	J	U	G	Y	T								
Supply voltage		[V]	12 V =	24 V =	98 V =	205 V =	110V at 50Hz/ 120V at 60Hz	230V at 50Hz/ 240V at 60Hz						
Tolerance supply voltage		[%]	±10	±10	±10	±10	±5	±5						
Current consumption hold		[A]	2.72	1.29	0.33	0.15	0.6 / 0.55	0.3 / 0.27						
Current consumption in rush		[A]	2.72	1.29	0.33	0.15	2.5 / 2.4	1.25 / 1.2						
Power consumption hold			32.7 W	31 W	31.9 W	30.2 W	70 / 70 VA	70 / 70 VA						
Power consumption in rush			32.7 W	31 W	31.9 W	30.2 W	280 / 290 VA	280 / 290 VA						
Solenoid connection		Connector as per EN 175301-803, solenoid identification as per ISO 9461 (code W).												
Wiring min.		[mm ²]	3 x 1.5 recommended											
Wiring length max.		[m]	50 recommended											

With electrical connections the protective conductor (PE ⚡) must be connected according to the relevant regulations.

Ordering Code

**Directional Control Valve
Series D1VW**

2

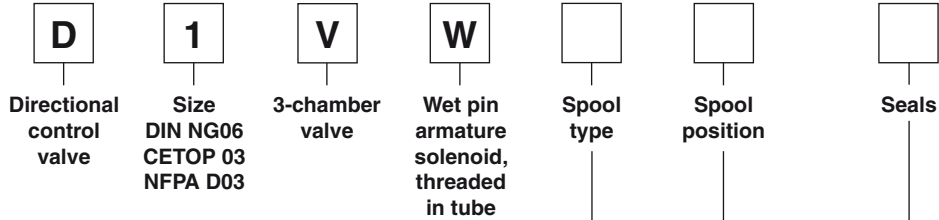

3 position spools	
Code	Spool type
001	
002	
003	
004	
005	
006	
007	
008 ¹⁾	
009 ¹⁾	
010	
011	
014	
015	
016	
021	
022	
031	
032	
034	
035	
061	
081	
082	
102	
204 ¹⁾	
205 ¹⁾	

Code	Seals
N	NBR
V	FPM

3 position spools			
Code	Spool position		
C		3 positions. Spring offset in position "0". Operated in position "a" or "b".	
	Standard	Spool type 008,009, 204, 205	
E		2 positions. Spring offset in position "0".	
F		2 positions. Operated in position "0".	
K		2 positions. Spring offset in position "0".	
M		2 positions. Operated in position "0".	

2 position spools			
Code	Spool position		
B		2 positions. Spring offset in position "b". Operated in position "a".	
D		2 positions. Operated in position "a" or "b". No center or offset position.	
H		2 positions. Spring offset in position "a". Operated in position "b".	

2 position spools	
Code	Spool type
020	
026	
030	
083 ¹⁾	
101	
208	

**Bold letters =
Short-term availability**

¹⁾ Consider specific spool position.

Ordering Code

2

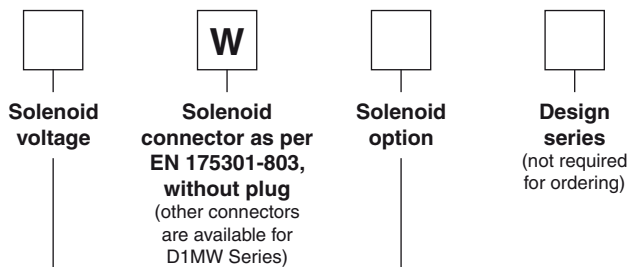

Code	Solenoid option
omit	Standard solenoid with manual override
T	without manual override
S2 ³⁾	Soft shift orifice size 0.5 mm.
S3 ³⁾	Soft shift orifice size 0.75 mm.
4N ³⁾	with lockable manual override

³⁾ DC only

Code	Voltage
K	12V =
J	24V =
U ²⁾	98V =
G ²⁾	205V =
Y	110V 50Hz / 120V 60Hz
T	230V 50Hz / 240V 60Hz

²⁾ Rectifier needed for DC solenoid when used with AC input.

Further spool types, solenoid voltages and connectors on request.

Flow curve

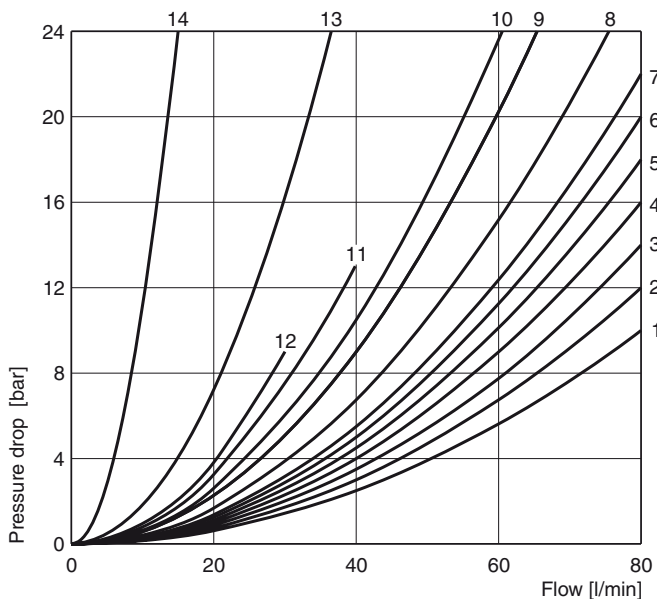

All characteristic curves measured with HLP46 at 50°C.

Spool	Position "b"			Position "a"			Position "0"				
	P-A	B-T	P-B	P-B	A-T	P-A	P-A	P-B	A-T	B-T	P-T
001	2	2		2	2						
002	1	4		1	4		1	1	5	5	2
003	3	4		3	6				7		
004	2	3		2	3				7	7	
005	2	2		2	2		12				
006	1	4		1	4		7	7			
007	3	2		2	2			3		2	7
010	3			3							
011	2	2		2	2				14	14	
014	3	2		2	2		3		2		7
015	3	6		3	4					7	
016	2	2		2	2			12			
020B	4	4		2	3						
026B	4			4							
030B	2	3		1	2						
034	4		8	3	3				5	7	
035	3	3		4		8			7	5	
081	13	13		13	13						
082	13	13		13	13				1)	1)	
101B	11	10		10	9						
102	1	4		1	4		5	5	8	8	6
61	1	3		1	3		3	2			
83H	5	2		5	2						
104	1			2	5		3		14		14
208	3			2							
	P-B	A-T		P-A	B-T		P-A	P-B	A-T	B-T	P-T
008	4	5		4	5						9
009	5	5		6	7						7
83B	5	2		5	2						
204	1	3		4	3		7		4		7
205	4	3		1	3			7		4	5

Spool	Position "b"			Position "a"		
	P-A	P-B	A-B	P-B	A-T	
021	2	4		4	2	
	P-A	B-T		P-A	P-B	A-B
022	6	2		5	2	
	2	2				
				2	2	

1) Only for pressure compensation, no high flow possible.

Shift Limits

The diagram below specifies the shift limits for valves with DC solenoids. Valves with spool position “F” or “M” can only be operated up to 70% of the limits. The specifications apply to a viscosity of 40mm²/s and balanced flow

conditions. The shift limits can be considerably lower at unbalanced flow conditions. To avoid flow rates beyond the shift limits, a plug-in orifice can be inserted in the P-port.

Valve with standard DC solenoid

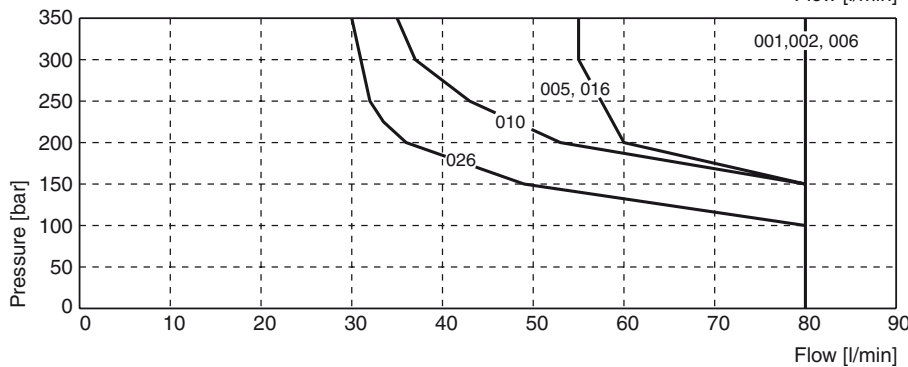
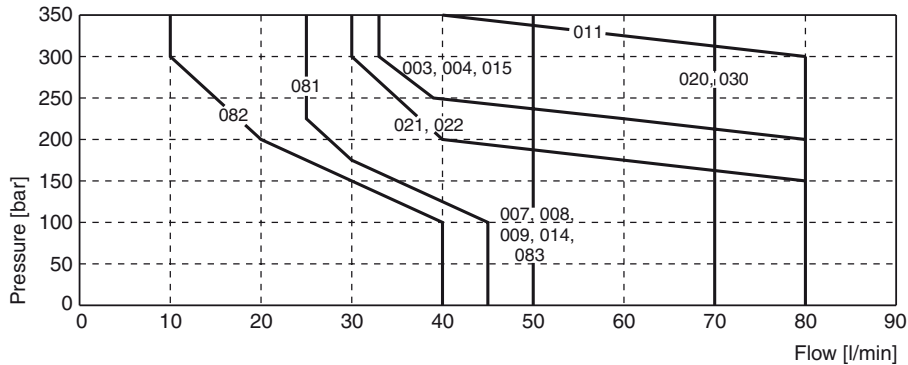

Measured with HLP46 at 50°C, 90% U_{nom} and warm solenoids

Valve with standard AC solenoid

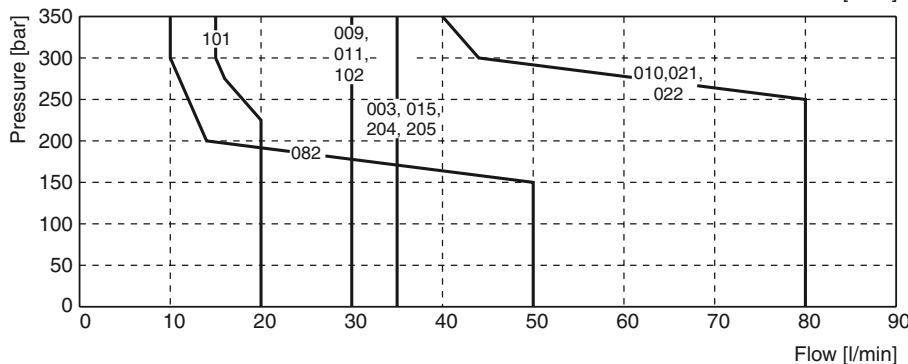
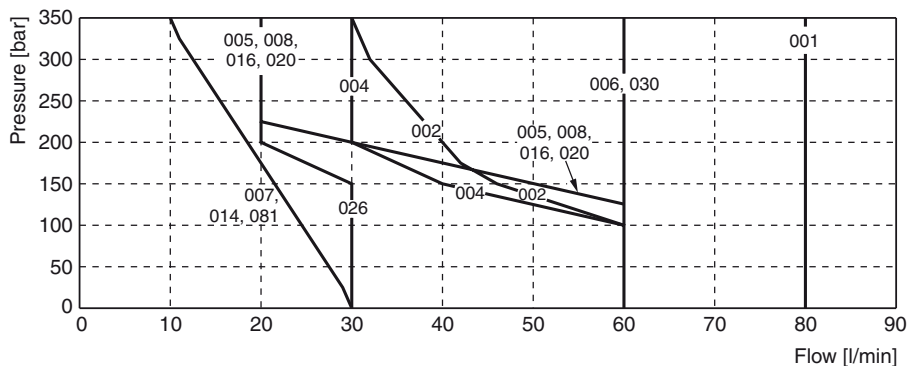

Measured with HLP46 at 50°C, 95% U_{nom} and warm solenoids

D1VW_UK.INDD CM_17.05.2010

Shift limit diagram - Soft shift with 1 DC solenoid

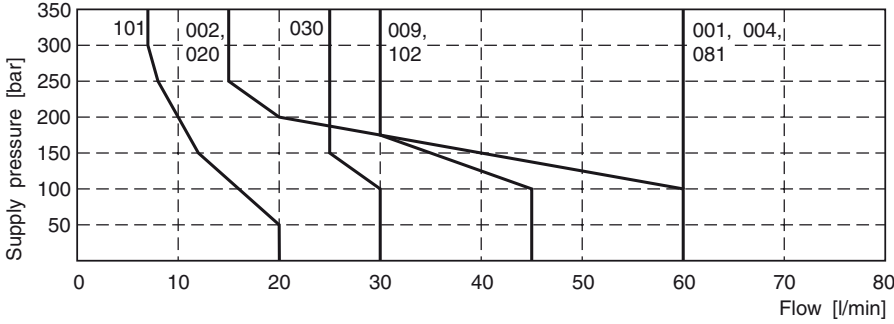

Shift limit diagram - Soft shift with 2 DC solenoid

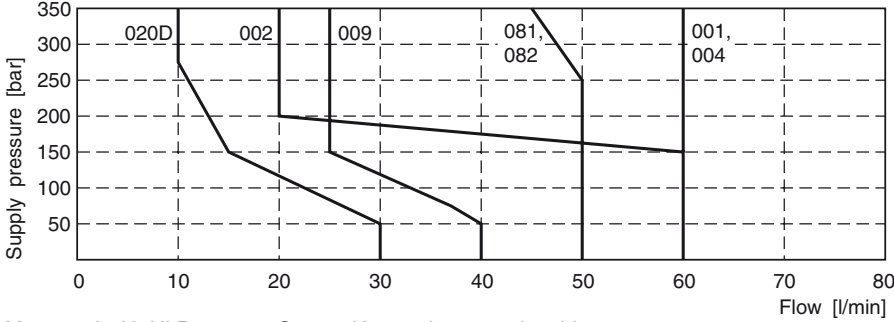

Measured with HLP46 at 50°C, 90% U_{nom} and warm solenoids

Response times D1VW Standard and Soft Shift

Standard solenoid		Energize	De-energize
Standard DC	w/o	45 - 60	20 - 30
Standard AC	w/o	13	20
Standard DC with rectifier plug	w/o	60 - 70	70 - 90

Response times Soft Shift	Orifice size	2 solenoid valve		2 solenoid valve		1 solenoid valve	
		3 positions		3 positions		2 positions	
		Center position: Closed		Center position: Open			
Code		Energize	De-energize	Energize	De-energize	Energize	De-energize
S2	0.50mm	200 - 750	310 - 650	220 - 400	350 - 750	90 - 350	160 - 500
S3	0.75mm	180 - 300	300 - 400	200 - 350	300 - 500	90 - 350	130 - 350

The lower value applies to small flow rates and low pressure, the upper value to high flow rates and high pressure

Step response times were obtained under the following conditions: HLP46 at 50°C with the valve operating at nominal pressure and flow. Published response times are nominal and may vary with spool, flow, pressure and temperature.

Acceleration for orifice size 0.75, code "S3" (measured against a standard valve)

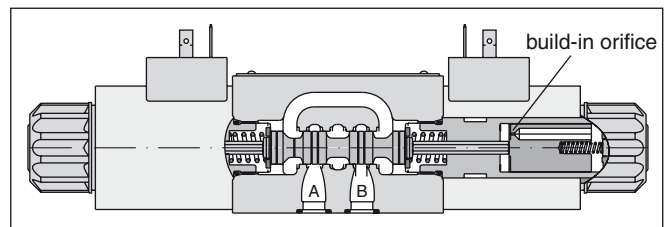

For even softer shifting, the proportional spools 081, 082, 101 and 102 can be used.

Dimensions

**Interface EN 175301-803, DC solenoid
B, E, F -style**

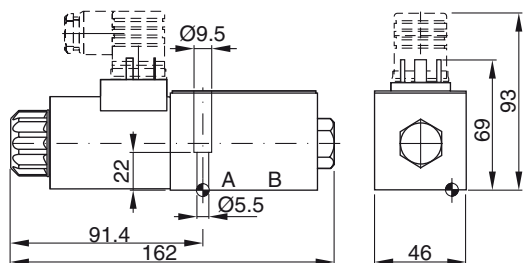

H, K, M -style

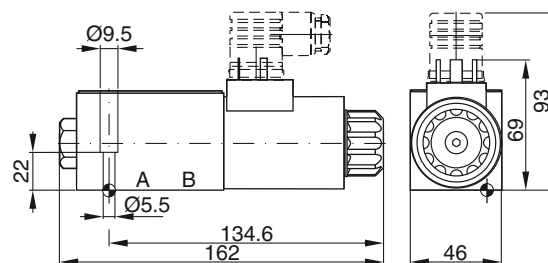

C, D -style

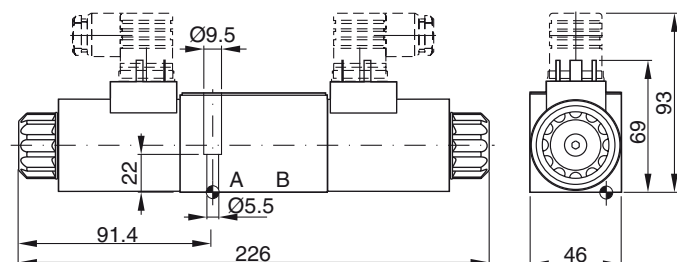

**Option 4N, with lockable manual override
(available for all styles, DC only)**

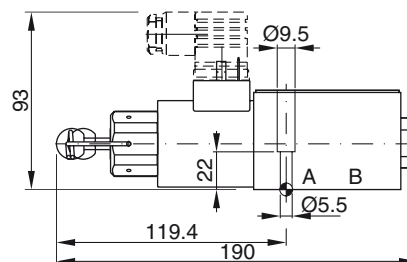

**Interface EN 175301-803, AC solenoid
B, E, F -style**

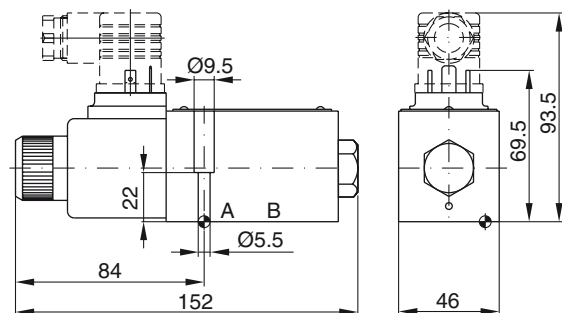



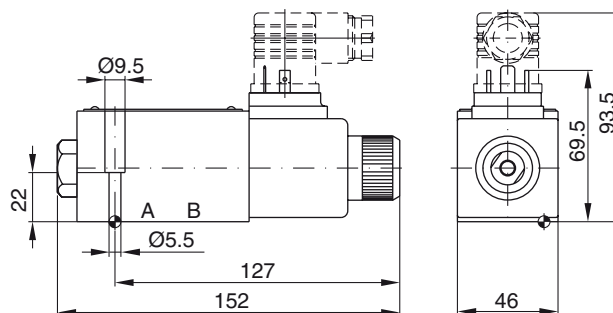

H, K, M -style

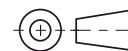
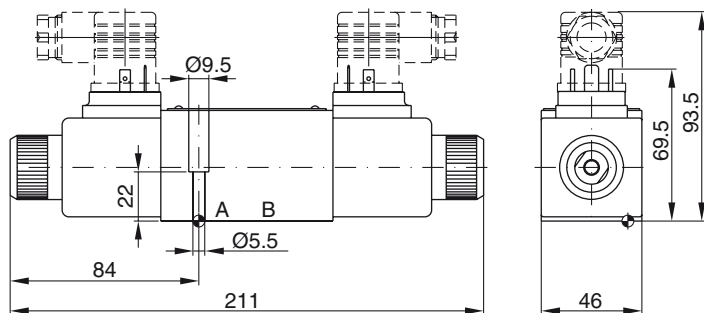

C, D -style



Surface finish	 Kit	 Kit	 Kit	 Kit
$\sqrt{R_{max}6.3}$ 	BK375	4x M5x30 DIN 912 12.9	7.6 Nm ±15%	NBR: SK-D1VW-N-91 FPM: SK-D1VW-V-91

The space necessary to remove the plug per EN 175301-803, design type AF is at least 15 mm.
The torque for the screw M3 of the plug has to be 0.5 to 0.6 Nm.

